

網路攝影機透視

摘自紐約時報

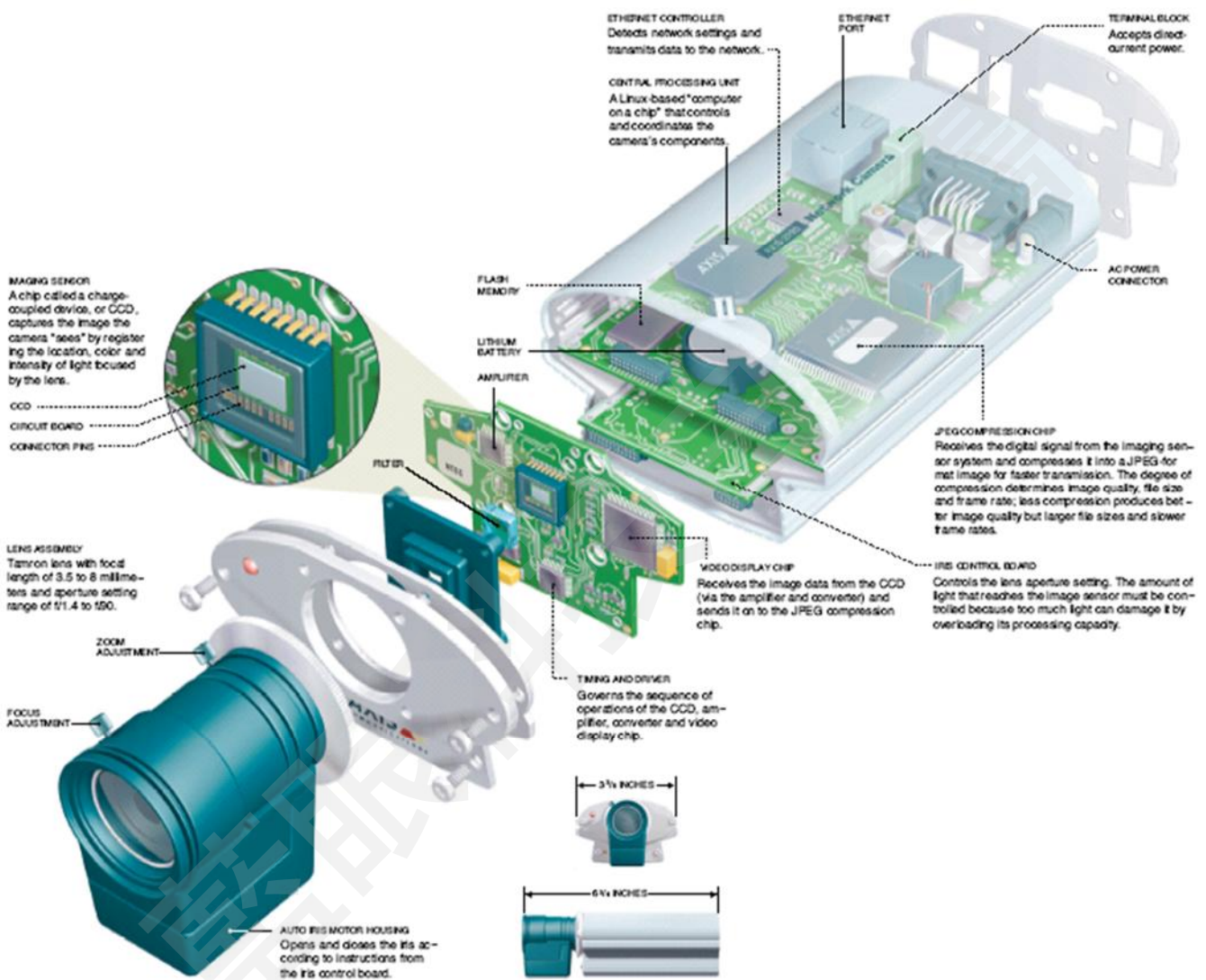

LENS ASSEMBLY

Tamron lens with focal length of 3.5 to 8 millimeters and aperture setting range of f/1.4 to f/90.

ZOOM ADJUSTMENT.....

FOCUS ADJUSTMENT.....

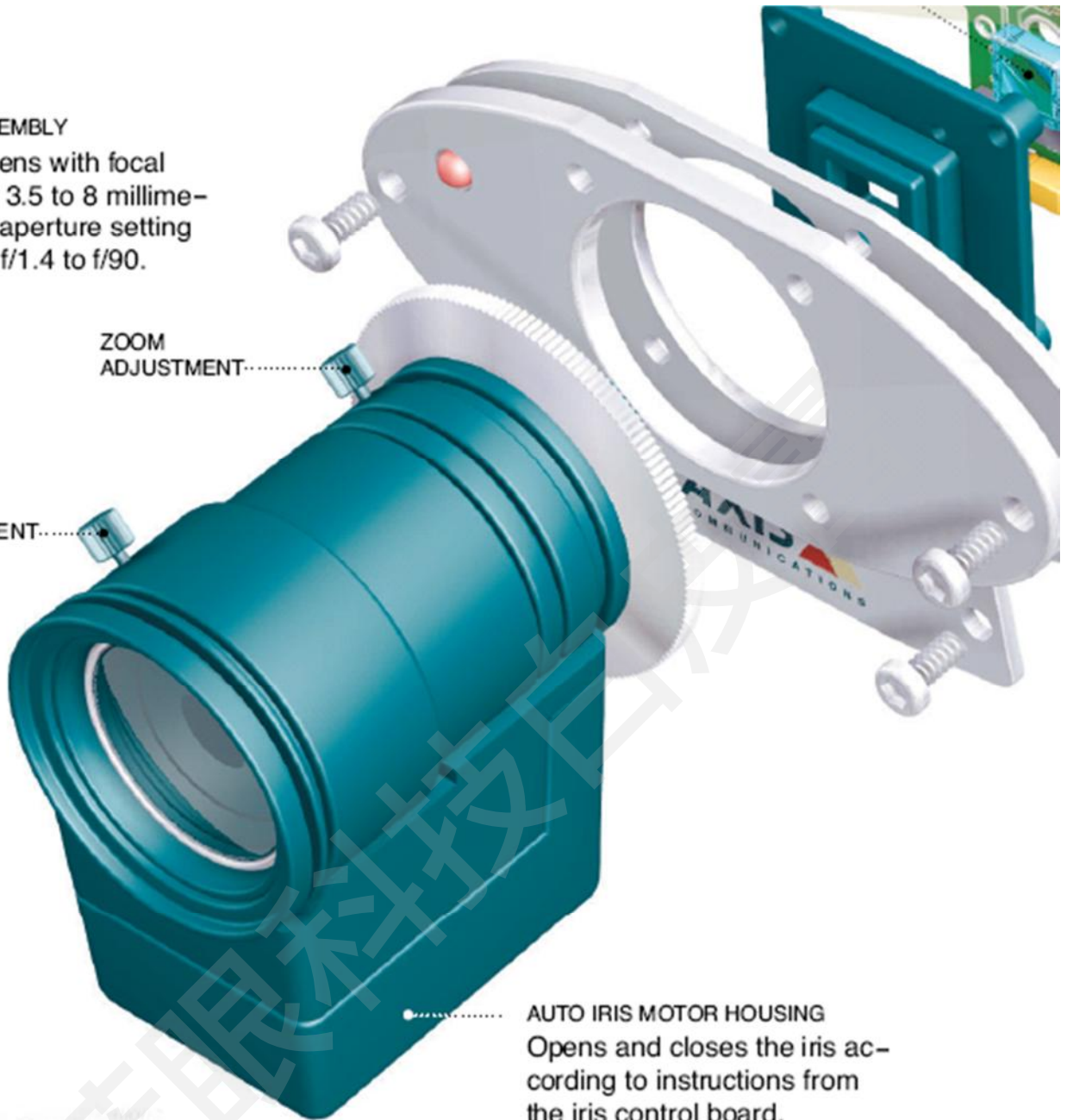

AUTO IRIS MOTOR HOUSING
Opens and closes the iris according to instructions from the iris control board.

IMAGING SENSOR

A chip called a charge-coupled device, or CCD, captures the image the camera “sees” by registering the location, color and intensity of light focused by the lens.

CCD

CIRCUIT BOARD

CONNECTOR PINS

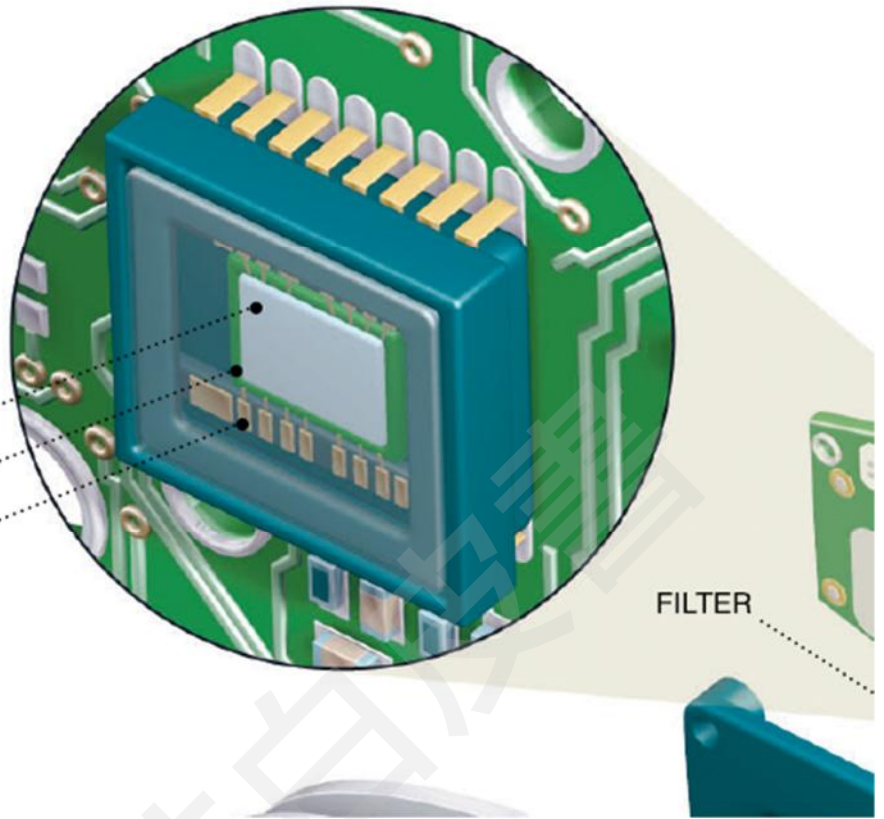

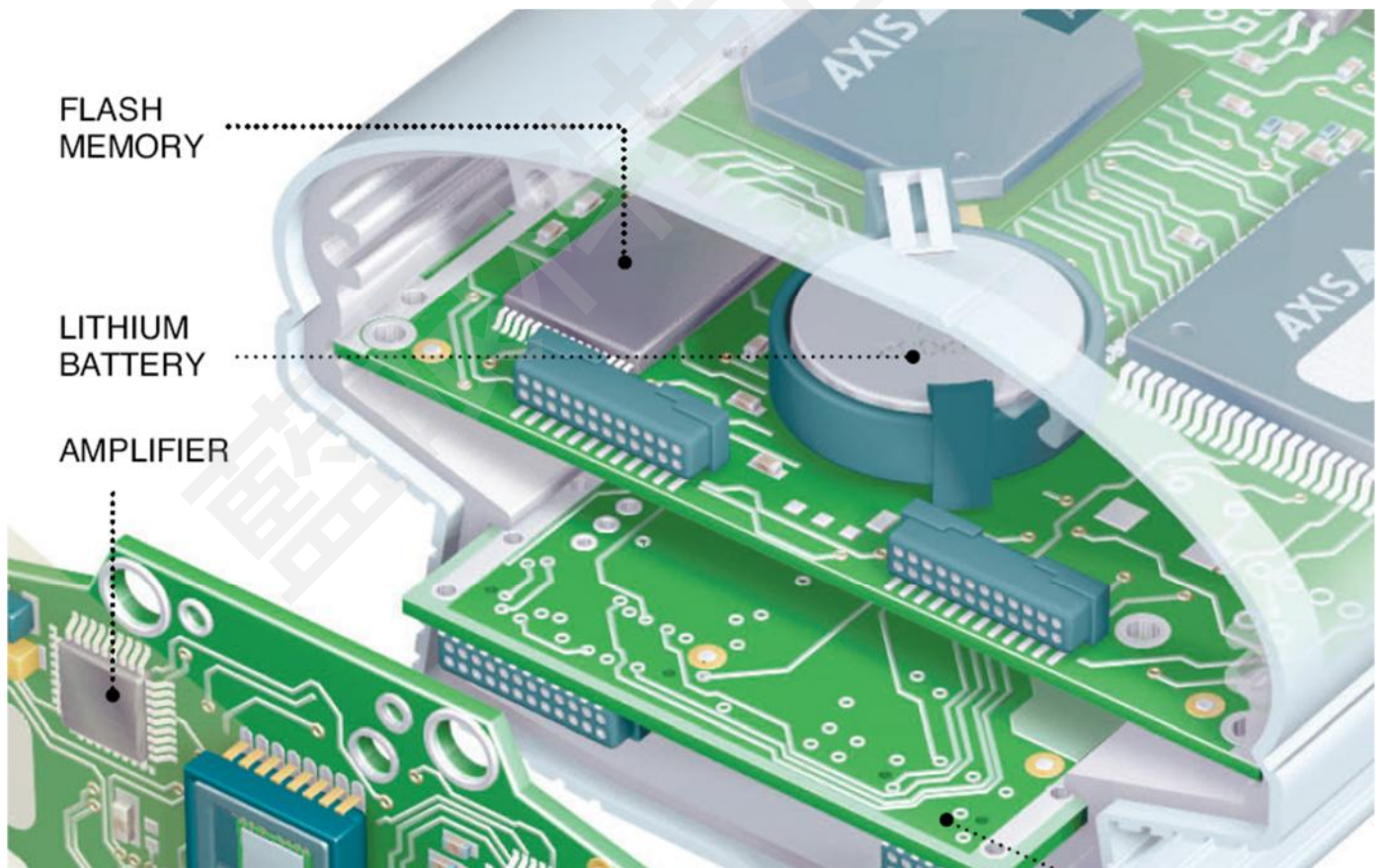
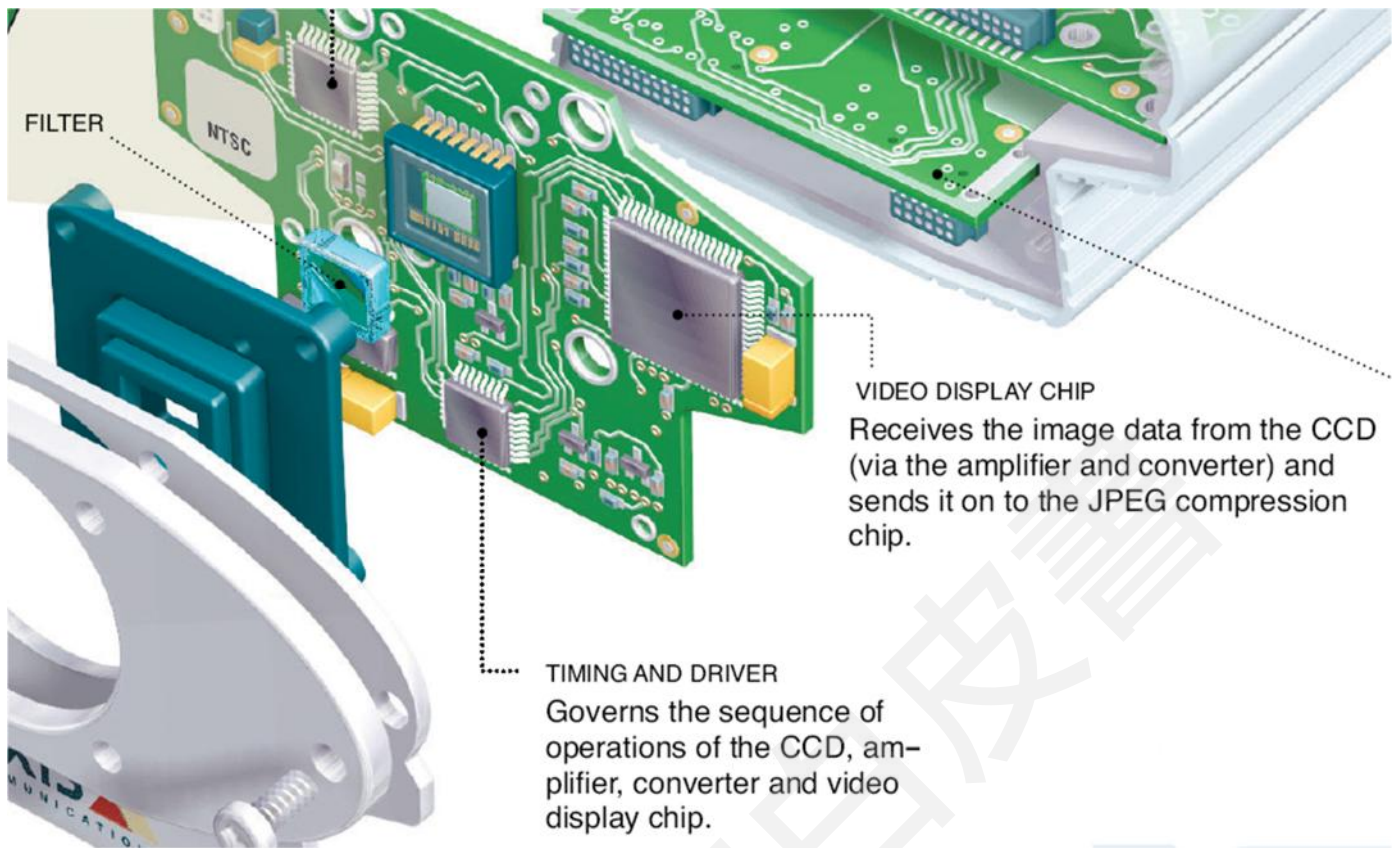

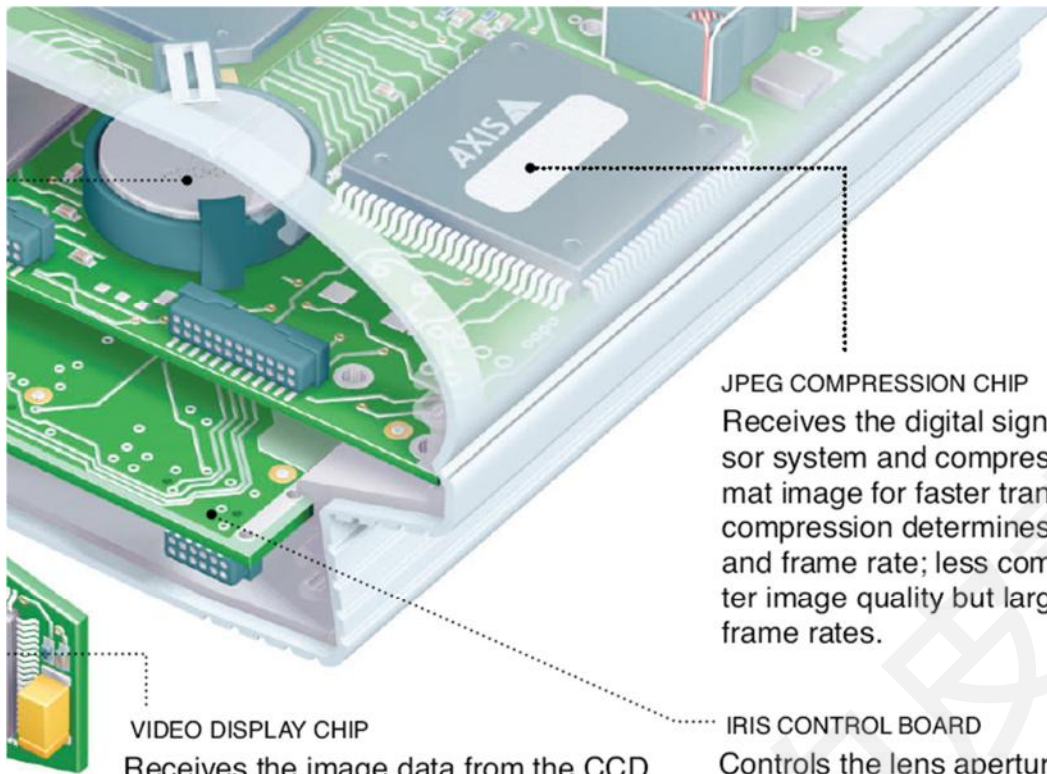

JPEG COMPRESSION CHIP

Receives the digital signal from the imaging sensor system and compresses it into a JPEG-format image for faster transmission. The degree of compression determines image quality, file size and frame rate; less compression produces better image quality but larger file sizes and slower frame rates.

VIDEO DISPLAY CHIP

Receives the image data from the CCD (via the amplifier and converter) and sends it on to the JPEG compression chip.

IRIS CONTROL BOARD

Controls the lens aperture setting. The amount of light that reaches the image sensor must be controlled because too much light can damage it by overloading its processing capacity.

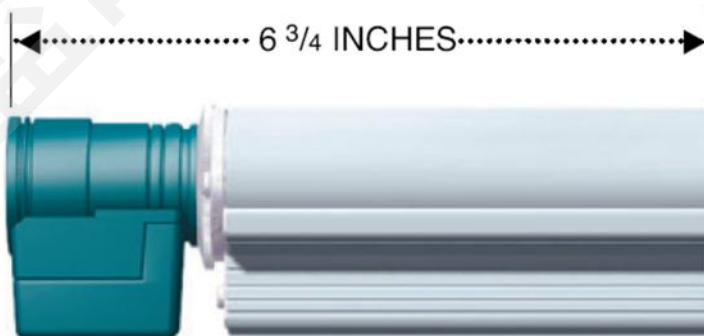
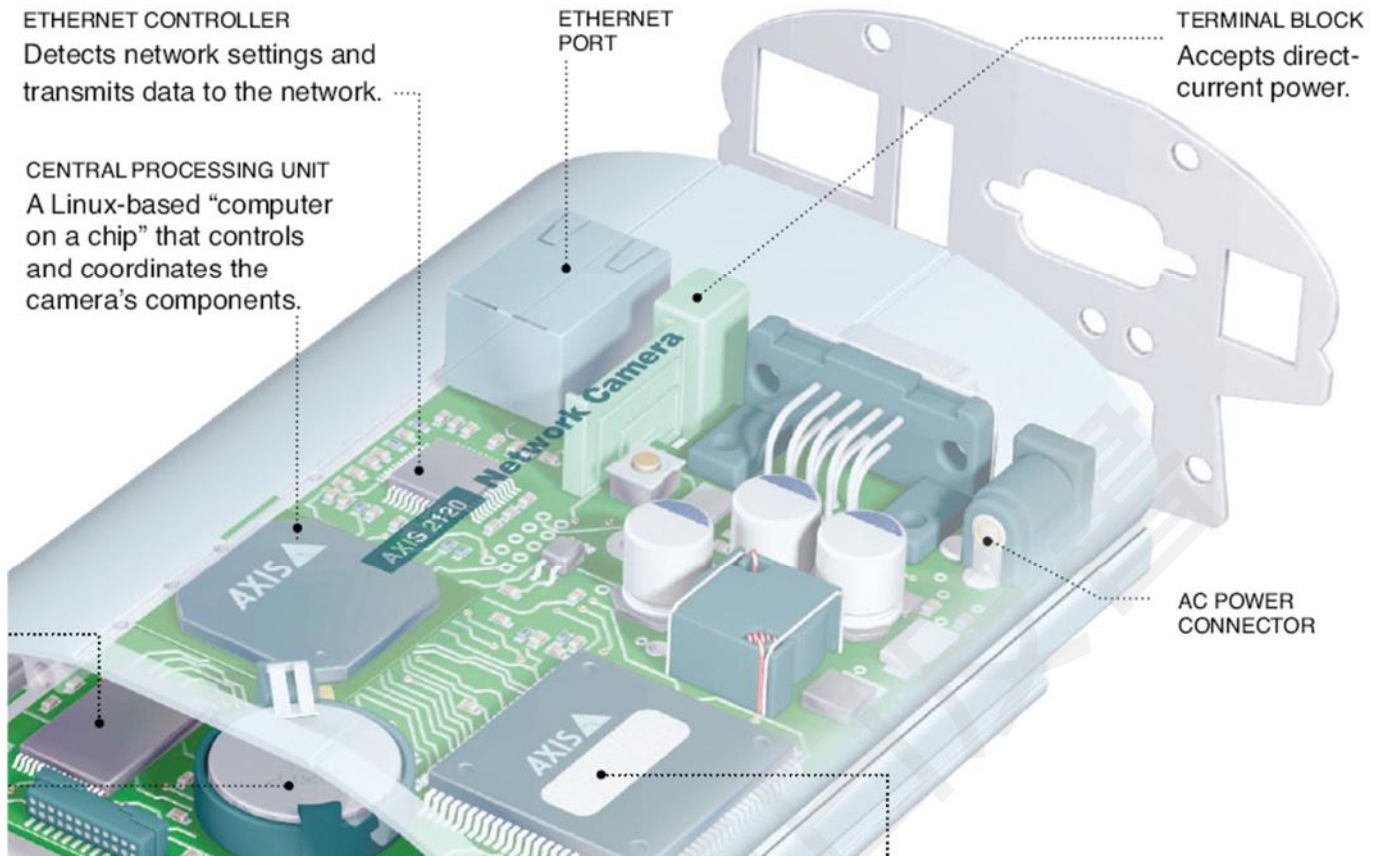

Reprinted From
The New York Times
Circuits

THURSDAY, APRIL 24, 2003

HOW IT WORKS

Online, All the Time, an All-Seeing Surveillance System

By JEFFREY SELINGO

In the 2001 remake of the film "Ocean's Eleven," a band of thieves switches surveillance cameras pointed at a Las Vegas casino's safe to a recorded image of a replica safe that they have built in a nearby warehouse. By the time casino officials discover that the safe they are monitoring is not the real one, the thieves are well on their way to making off with \$150 million.

Fooling security systems always seems to work in Hollywood. But in real life, it's not so easy these days. Not only are surveillance cameras more common in this era of increased concern about security, but they are also much more sophisticated.

Such systems no longer depend on a limited number of analog cameras with dedicated fiber optic wiring and banks of monitors connected to video recorders. Today, so-called network cameras use digital images, which can be easily stored

Instantly Before Your Eyes

Tiny digital video cameras can send images to a server computer for storage or archiving or ship them directly to the Internet. Such cameras add flexibility to surveillance and control systems and can offer consumers constant updates on matters like traffic and weather conditions.

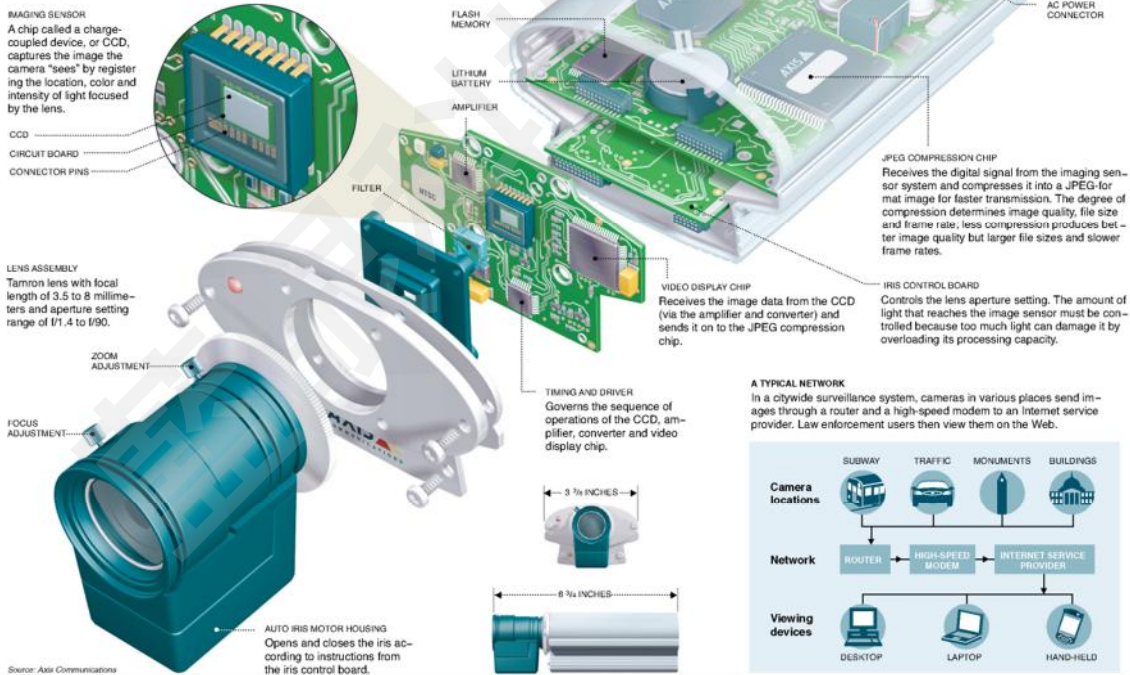

A TYPICAL NETWORK
 In a citywide surveillance system, cameras in various places send images through a router and a high-speed modem to an Internet service provider. Law enforcement users then view them on the Web.

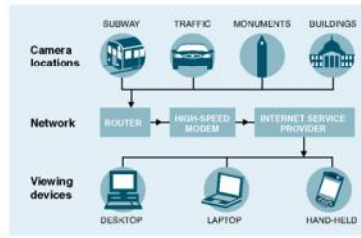

The New York Times; illustration by Frank O'Connell

and manipulated on a computer server and monitored from remote locations by using the Internet. Tiny cameras can be added to a security system, sometimes for temporary use, by simply hooking them up to a computer network. It is even possible to route video from analog cameras through servers that turn their images into digital pictures.

"Two PC servers can now do all the recording that used to take 100 VCR's," said Fredrik Nilsson, director of business development for Axis Communications, a Swedish company that sells network video cameras.

The systems have become popular with school officials and managers of shopping malls and convention centers and with local and state transportation departments, which provide live pictures that motorists can view over the Internet before heading out. "The biggest advantage is that it uses the existing infrastructure," Mr. Nilsson said. "It's as easy as plugging the camera into a computer network."

But the ease with which the high-tech surveillance cameras can be set up and used worries people who are concerned about the invasion of privacy. The Washington Police Department came under fire for a system it purchased from Axis that enables it to monitor activities through a network of cameras mounted at busy intersections, in

the subway system and at tourist sites like the National Mall.

The system, which is activated during heightened terror alerts, allows the authorities to manipulate the cameras so they can, for instance, pan and zoom in on activity they consider suspicious. The remote access also means that officers can view images on computer monitors installed in squad cars.

Axis also supplied cameras to the Salt Palace Convention Center in Salt Lake City for the 2002 Winter Olympics. Bart Allen, director of operations at the convention center, which continues to use the system, said the cameras were economical and improved security. With the center's old analog system, he said, security guards could record the images from only 5 of the 80 cameras located around the center at any one time. "So if something happened in an area we weren't recording, we didn't have a record of it," Mr. Allen said. Now, images at all 80 locations can be recorded.

What's more, because cameras can easily be added or moved anywhere a network connection is available, the system can cover much more ground than an analog system. If a vendor brings valuable equipment to a trade show at the convention center, for example, Mr. Allen said, he can set up a camera to watch it. Network

cameras can be programmed to record only when there is movement in the field of vision so that no computer memory is wasted on monitoring empty rooms. And it is easier to find a specific moment on a digitized video, as anyone who has tried to locate a specific scene in a movie on a DVD or a videotape knows.

The new system has already foiled burglaries at the convention center, Mr. Allen said. "We put a camera on a bunch of laptops in a room and we ended up catching one of our own security guards helping himself to a few of them," he said. "Big Brother is everywhere."

Sean Grogan, vice president for operations for Springfield Food Court, a company that operates food courts in shopping malls and airports, said he was attracted to the network cameras because they can store a digital archive at little cost. With his old analog system, he had a videotape for each day of the week. Each Tuesday, for instance, he taped over the previous Tuesday's tape.

When the company was sued recently by an employee who claimed to have fallen at work four months earlier, Mr. Grogan was able to find the digital images from that day on his computer server. It showed that no one had fallen, he said. "If we had the old system," he said, "it would have been my word against theirs."

Copyright© 2003 by *The New York Times Company*. Reprinted for web use with permission.
Reprinted by Seoop ReprintSource 1-800-767-3263